

Kit — Welded Picket Installation Instructions

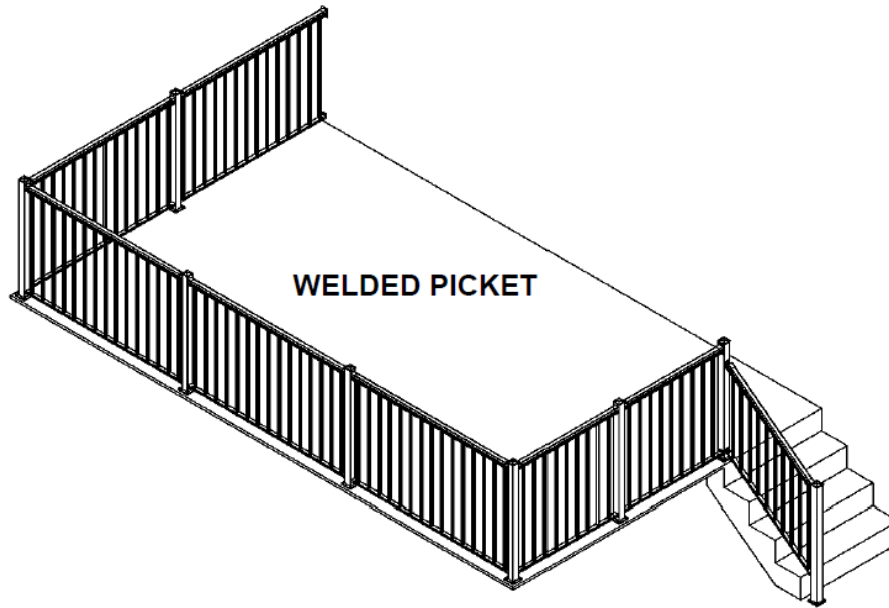

TOOLS & MATERIALS REQUIRED

- 10" Miter (w/ Carbide Triple Chip Blade) or Hacksaw
- Tape Measure
- Electric power cords
- Pencil
- 1/8", 5/32", 3/16", and 1/4" Drill Bits
- Cordless or Electric Drill, variable speed
- Level
- Hammer Drill for concrete or stucco applications
- Exact-o-knife
- NP1 Urethane Caulking and Caulking Gun
- Robertson #2 Bit Head
- Straight Screw Driver (Chicago Bolts)
- Hex Head Driver Bits (#10 Tek & #14 Tek)

WARNING

No representation or warranty is given that your particular application of these products complies with relevant building codes or that the fasteners provided or used are appropriate for your application. Therefore consult with professionals and local building officials before beginning work; (i) to ensure compliance with relevant building codes for your application and for your proposed use of fasteners; (ii) to ensure the integrity of the structural components in connection with which these products are to be used (iii) to identify appropriate safety gear that is to be used during installation such as safety harness when working above ground; (iv) to ensure that the work area is free from utilities, services and hazards; and (v) to clarify any instructions or warning that may not be clear. Always work in a safe manner wearing protective gear such as gloves, eyewear, headwear, footwear and clothing. When using tools always comply with operating manuals and instructions. Metal and glass may have sharp edges and could fragment or splinter during or as a result of handling or cutting. Do not use these products in connection with any substance that is or may be harmful or corrosive to the products. Inspect and maintain these products and the structural components that they are used in connection with on a regular basis using professionals when appropriate. These instructions have been prepared for certain standard residential applications. Obtain professional advice for any non-standard or non-residential application.

.....

No member of Excell Railing Systems shall be liable for any loss or damage resulting from improper installation or use of this product. In the unlikely event that any member of Excell Railing Systems becomes liable for any loss or damage, the aggregate liability shall be limited to the retail purchase price of the product.

Kit — Welded Picket Installation Instructions

STEP 1: POST SETUP

- a) Based on your deck layout, place posts on the deck equally spaced apart. Ensure mounting area has adequate solid blocking.

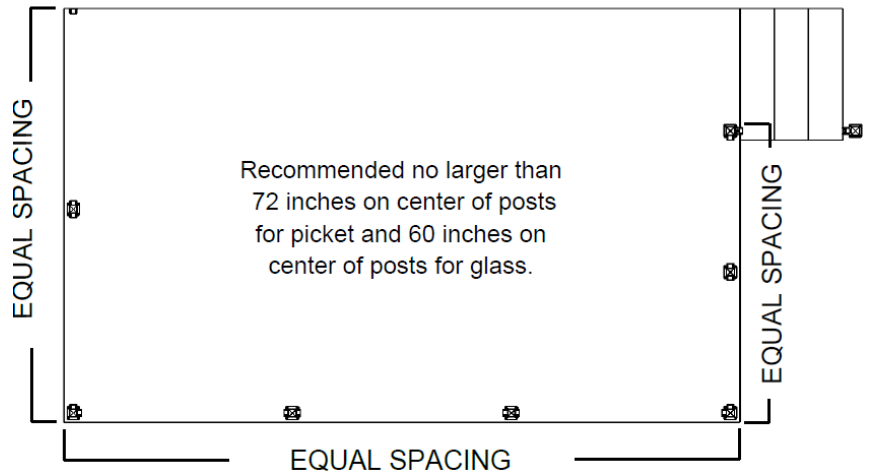

- b) Once you have the posts placed into their positions, (approx. 2" from edge of the post base plate to edge of deck), pre-drill and loosely fasten the post to the deck with 1 fastener leaving 1/2" above the post base plate.

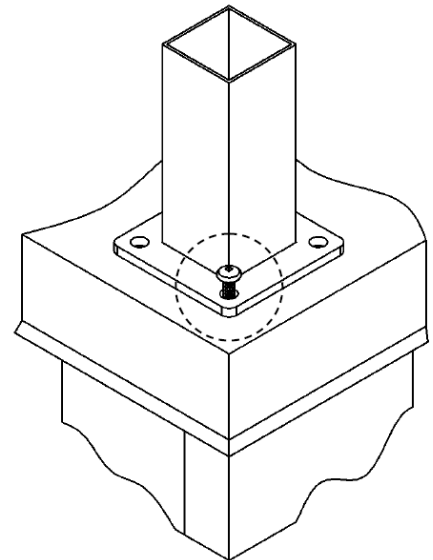
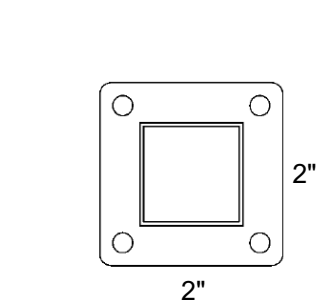

- c) Starting at one end of the deck, plumb the end post, and secure all four fasteners. If you are wall mounting at the starting point, see step 2b. Some vinyl or rubber gasket can be used as shims under the base plates for these adjustments. Once you are satisfied with the adjustments pre-drill the remaining 3 holes in the deck, put a little NP1 Urethane Caulking onto the threads of the screws. Just snug the screws down, and do not over tighten (don't forget to back out the original fastener and apply the NP1 Urethane Caulking). As railing becomes secure, once again, double check posts are plum and square.

Note: Use NP1 Urethane Caulking for attaching the railing mounts to the building or wall too.

Kit — Welded Picket Installation Instructions

STEP 2: INSTALLING WELDED PICKET PANELS

- a) Position and hold the welded picket panel up to a post to post span. Centering the pickets between the posts. Using a pencil, mark the top and bottom rail on each side to the inside of the post. Deduct 1/2" on each side, and then cut the top and bottom rail.

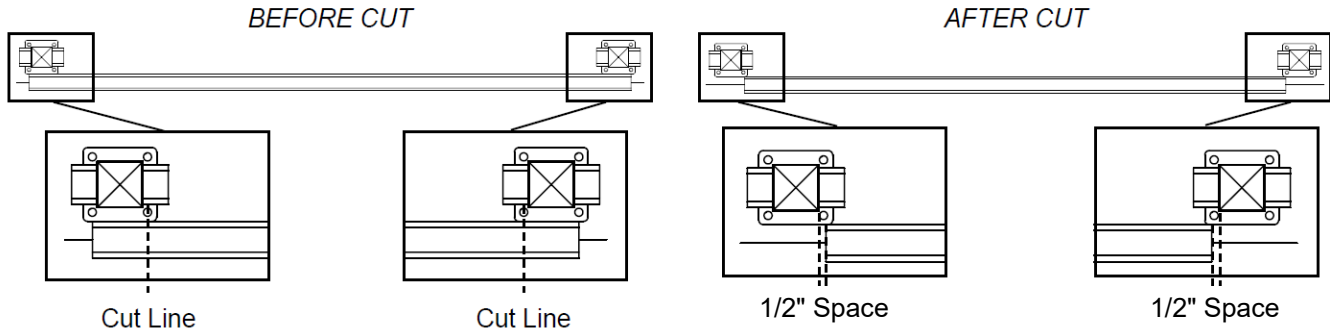

NOTE: Picket to post spacing should be no larger than 4 inches.

- b) Join the railings together by sliding top and bottom rail into the post sleeves or into a loose wall mount.
NOTE: If you are mounting to a wall or column, (a) slide the loose wall mounts onto the top and bottom rail (b) measure and mount to wall or column.

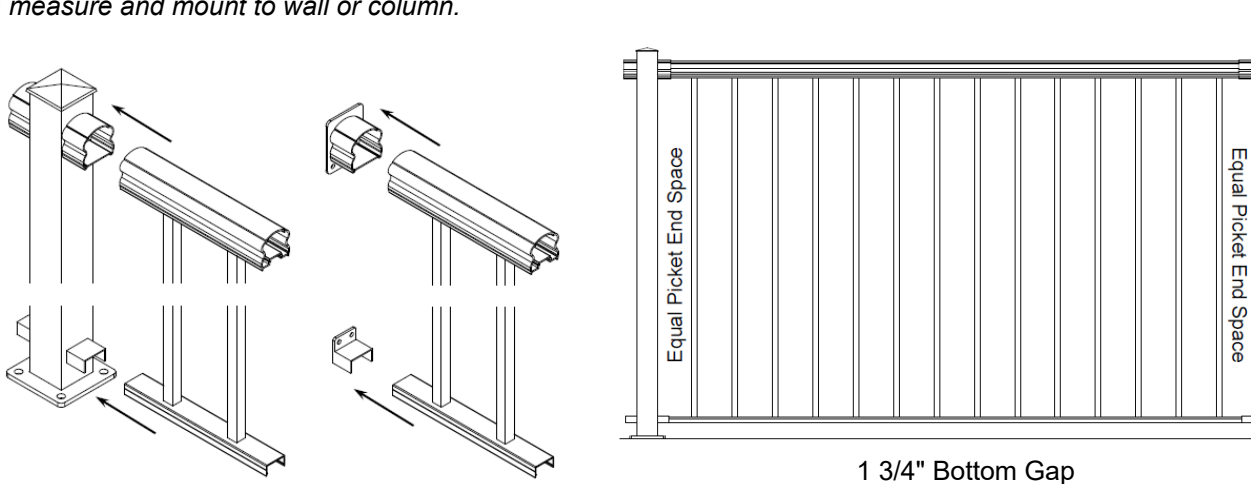

- c) Secure the top rail to the top sleeve using a #10 x 3/4" tek fasteners under the top sleeve and secure the bottom rail to the bottom wall mount using a # 10 x 3/4" tek fasteners on the outside of the deck.
- d) Slide your support leg under center line of bottom rail. Needed on spans of 48" or larger.
Example: 6'-0" - 1@3'-0" / 10'-0" - 30" apart. Secure with one TEK screw.

Repeat step 2 with the remaining welded picket sections

NOTE: Now that installation is complete, clean the railing of fingerprints using Vim or car polish.