

Fascia Mounted Cable Railing Assembly

36" RAIL HEIGHT = 10 LINES
42" RAIL HEIGHT = 12 LINES

SEE FASTENER SHEET
FOR FASTENER LISTINGS

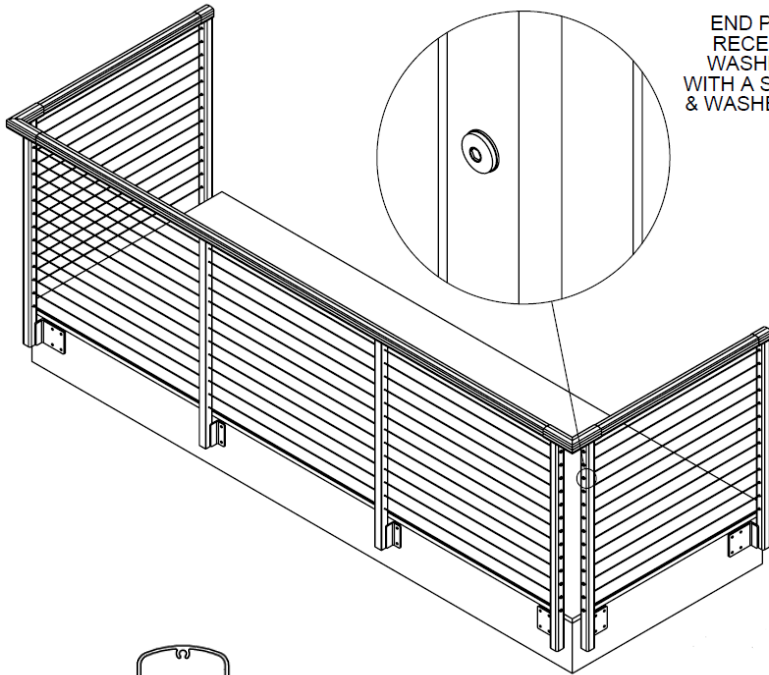

END POSTS TO HAVE
RECEIVER FITTING &
WASHER AT ONE END
WITH A STOP-END FITTING
& WASHER AT THE OTHER

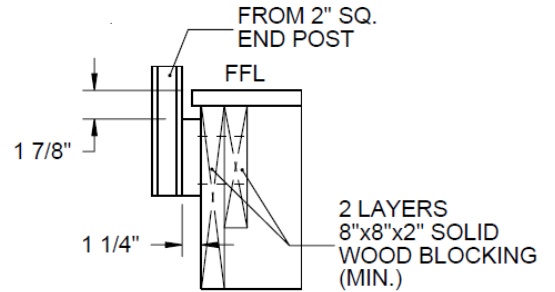

**FASCIA POST
CONNECTION DETAIL**

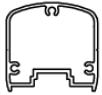

**EXCELL SQUARE
WELDED PICKET
TOP RAIL**



1.72" INLINE POST WITH
2"x2"x3/8" ANGLE x5"H
BASE PLATE (AT BOTH SIDES)



2"x2"x3/16" END POST WITH
2"x6"x3/8" ANGLE x5"H
BASE PLATE

3 1/8" CONSECUTIVE
DRILL HOLE SPACING

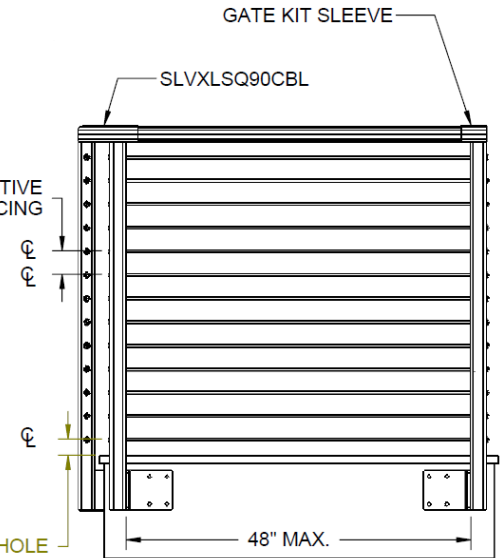

3" FIRST DRILL HOLE

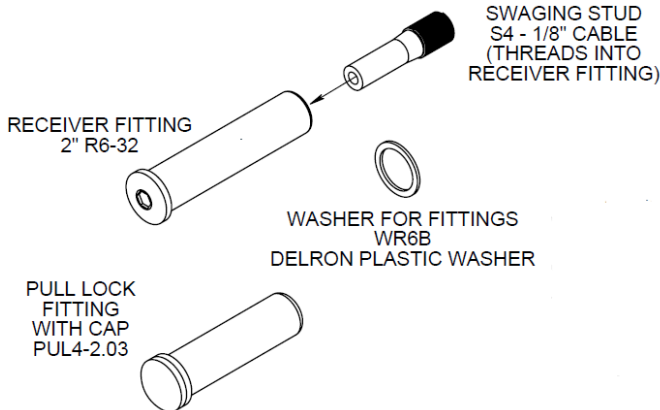

SWAGING STUD
S4 - 1/8" CABLE
(THREADS INTO
RECEIVER FITTING)

	CABLE SIZE	DRILL HOLE SIZE
INLINE	Ø 1/8"	Ø 1/4"
TENSION	Ø 1/8"	Ø 15/32"
	13	1
	14	4
	15	6