

Component Glass Installation Instructions

Please Note: Aluminum Railing is only as strong as what it is attached to. The installer must ensure that all mounting screws for post base plates and wall mounts are mounted into solid material with backing. Failure to fasten the mounting screws into solid material (deck joists or wall studs) will weaken the installation.

Before you install any railings, review the deck layout drawing and your bill of materials required for the project. Double check there is no damage to the product from transportation and the quantities of all materials received are correct, against the packing slip supplied with the order.

1. If you're using bottom receiver clips on posts, determine which posts need receiver clips and where they should be placed on the post. Then using the "Rail Clip Jig" pre-drill and attach clips with #10 x 1 1/2" #8 head screws. If using bottom rail wall mount sleeves on posts, install them at step #13.
2. Based on your deck layout information, set posts on the deck in their approximate locations. Ensure mounting area has adequate solid backing. Do not screw posts down at this time.
3. Once the post location is determined, using a tape measure, calculate equal and balanced spacing between posts in each railing run. With posts set in their final locations, use a pencil and mark mounting holes location; remove the post and pre-drill holes in the deck. Set posts back in place and mount only one screw, just snug enough to hold the post in place and prevent it from falling over. Do not use sealant on the mounting screws at this time. **Note:** If mounting to concrete use the recommended base plate Neoprene Gasket.
4. Place top rail sleeves loosely in posts where required. Do not fasten sleeves to posts at this time. **Note:** Trimming down some posts maybe required to allow for sleeves, stair angles or deck irregularities.
5. Once all the posts and sleeves are set in place, check that the posts are relatively plum to the deck and square to the building. Some vinyl or rubber gasket maybe used as shims under the base plates for the adjustments. Final adjustments will be made when the mounting screws are anchored.
6. To determine the length of the top rail, inspect the top sleeves to see how far the top rail will enter inside the sleeve and or wall mounts. Measure, calculate and record the top rail cut lengths from sleeve to sleeve for each run of railing. With all top rail measurements recorded, calculate the cuts out of the supplied material from your order. **Note:** Cut the largest rail piece first, progressing down to the smallest piece. This will maximize material usage.
7. The remaining posts without sleeves on them will require a Post Mount Component Plate for level rail and a Post Mount Stair Plate for stair rail. These post mount plates will connect the post to the underside of the top rail. These component parts can now be attached to the top of the posts with #10 x 3/4" or #10 x 1 1/2" screws.

Continued next page...

Component Glass Installation Instructions (Continued...)

8. Stair posts need to be cut to size to fit the stair angle. This can be done by holding the top rail at the required height and on the correct angle to one side of the post. Using a pencil, mark the post on the angle at the correct height. Keeping in mind the thickness of the post mount stair plate. **Note:** Measure twice, double-check and then cut once.
9. Now, that all the sleeves are in place and post mount plates are attached you can install the top rail. Lift the sleeves off the posts, insert the top rail into the wall mounts and sleeves, and then rest it back down onto the posts mounts. Ensure there is a maximum and/or equal amount of top rail is inserted into each sleeve.
10. Check for correct railing height by double-checking the railing is level and the posts are square and plum. When everything looks right, using #10 x 3/4" self-tapping screws, attach sleeves to top rail from the underside and then attach the posts to the sleeves from the outside of the deck.
11. Once all the top rails and sleeves are fastened into place, it's time to permanently screw down the posts to the deck. Insert the plastic shoulder washers into the base plate mounting holes. Put a little NP1 Urethane Sealant into the already pre-drilled holes and a little on the threads of the screw. Just snug screws down and do not over tighten. As railing becomes secure, once again, double check railing is straight and level, and the posts are plum and square. Shimming under the post base plates with vinyl or rubber gasket maybe required. **Note:** This is the same process for attaching the railing mounts to a building or wall.
12. When using receiver clips attached to posts, measure and record all the exact distances between posts from receiver clip to receiver clip. With all bottom rail measurements recorded, calculate the cuts out of the supplied material from you order. **Note:** Just like you did with the top rail, cut the largest piece first, progressing down to smallest piece, this will maximize material usage.
13. When using bottom rail wall mounts to posts, inspect the sleeves to see how far the bottom rail will enter inside the wall mount. Measure and record the distance between the posts and deduct for each sleeve. (Aprox. 1/2") With all bottom rail measurements recorded, calculate the cuts out of the supplied material from you order. **Note:** Just like you did with the top rail, cut the largest piece first, progressing down to smallest piece, this will maximize material usage.
14. Slide a component support leg into the bottom rail before installing, this will determine equal bottom gap around the deck. (1 3/4") Double check bottom rail is parallel with the top rail and looks inline with the deck surface. Some smaller glass openings may not need a component support leg.
15. Slide the support leg to the center of the glass opening, then pre-drill, seal and secure to the deck in the same manner as the posts. Cut top and bottom glass insert to fit openings and snap into place.

Continued next page...

Component Glass Installation Instructions (Continued...)

9. Measuring for glass should be done after frame installation is complete. This is in case of alterations required to the job site during the installation process. Allow a 1" to 3" spaces between the glass and posts or walls. This allows wind to pass through the rail and hand clearance for easier installation of the glass. Glass height should be $\frac{3}{4}$ " larger then the opening from top insert to bottom insert.
10. Glass can now be installed by sliding it up into the larger top insert first, then aligning it with the smaller bottom insert and push it down into place. **Note:** A small amount of dish soap along the insert surface may help this process.
11. Now that installation is complete, clean the rail and glass of fingerprints, then double check the railing for scratches or scuffs. Most imperfections can be cleaned or rubbed away using Vim or car polish.
12. If touch up is required, make sure the surface is clean and free of all contaminants. When applying touch up paint, try to use as little as possible and only in the scratched spot. This will help avoid attraction to the defective area. Once dry, some car polish or rubbing compound may help blend the painted surface.
13. Once everything is complete have the owner inspect the installation for final approval.

Tool Requirements for Railing Installation

- ◆ 10" Mitre Saw with a Carbide Triple Chip Blade
- ◆ Electric or 18-volt cordless, variable speed Drill
- ◆ Hammer Drill for concrete or stucco applications
- ◆ Electric power cords
- ◆ Drill bits - 1/8" & 5/32" & 3/16" & 1/4" (bring extras)
- ◆ Driver bits #2 & #3 - 6" long Robertson head (bring extras)
- ◆ Hack Saw
- ◆ Safety Glasses
- ◆ Ear Protection
- ◆ Tape Measure
- ◆ Pencil
- ◆ Exact-o-Knife
- ◆ Pliers or Vice Grips
- ◆ 3' Level
- ◆ Framing Square
- ◆ String line
- ◆ Hammer
- ◆ Metal File
- ◆ Non-Marking Rubber Mallet
- ◆ Dish soap for glass installation
- ◆ Tin Snips, center cut or Yellow handle
- ◆ Caulking Gun
- ◆ Bottom Rail Clip Jig

EXCELL
 RAILING SYSTEMS LTD
 #306 - 12886 Anvil Way Surrey, BC V3W 8E7
 Phone: 604-501-0151 Fax: 604-501-0155
 Toll Free: 1-866-999-7245 www.excellrailing.com

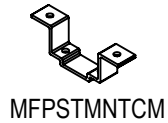

Drawing Name:
 PST172 Glass Rail

Customer:
 Excell Railing System

Project Name:
 Excell Railing System
 #306 - 12886 Anvil Way
 Surrey, BC Canada V3W 8E7
 Phone: 604.501.0151

Dwn By: Rolly Gatus Chk'd By: BH

Date Created: 20200519

Scale: Not To Scale

GENERAL NOTES:

- MATERIALS:**
- Aluminum alloy and temper:
 Posts 6005A-T61
 Rails 6063-T5
 Baseplate 6005A-T61
 - Design Specifications and Standards for Aluminum Structures Aluminum Association
 - Screws for railing system assembly as per manufacturer's specification
 - Glass infill panels
- POWDER COATING SPECIFICATION:**
- Finished powder coat color is TBD
 - Powder coat meet AAMA-2604-02 Voluntary Specifications.
- Performance Requirements and Test Procedures for Pigmented Organic Coatings on Aluminum Extrusions and Pickets.**
- OTHERS:**
- Rail assembly to meet all specification requirements as stated in attached
 - Contractor to field verify all dimensions and quantities prior to fabrication

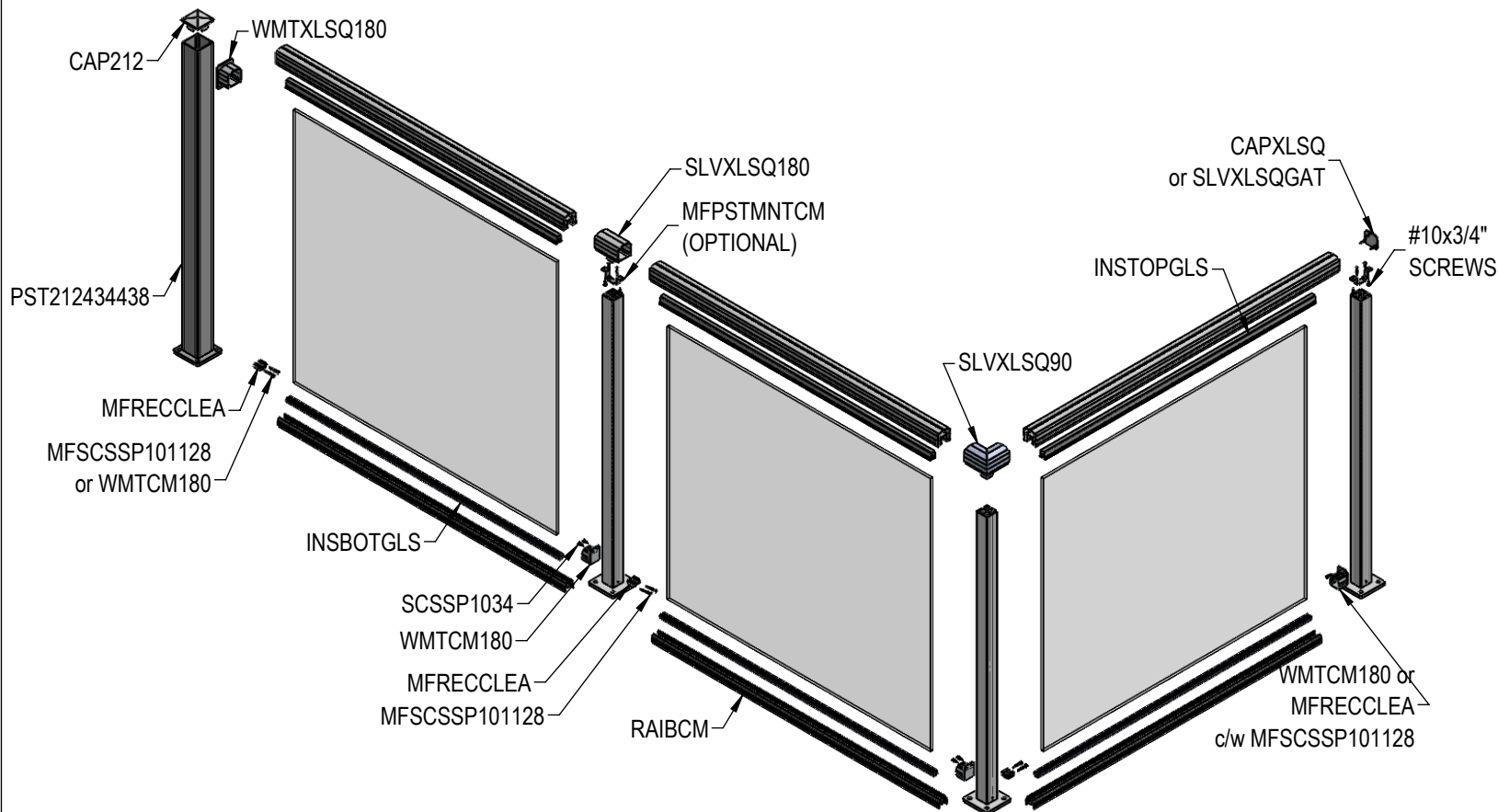

ALL DIMENSIONS ARE SUBJECT TO SITE MEASUREMENTS AND ARE TO BE CONFIRMED BEFORE FABRICATION OF PRODUCT

ENGINEERING STAMP & DATE

-	-	Per E-Mail received (date)
No.	BY	Revision

Center Post with Continuous Top Rail Detail - Component Glass

BILL OF MATERIALS

1. Top Rail (Square or Round)
2. Top Glass Insert
3. Tempered Glass (6mm / 1/4")
4. Bottom Glass Insert
5. Component Bottom Rail
6. 180° Top Sleeve
7. Post (2" or Less)
8. (a) Receiver Clip OR (b) Bottom Wall Mount

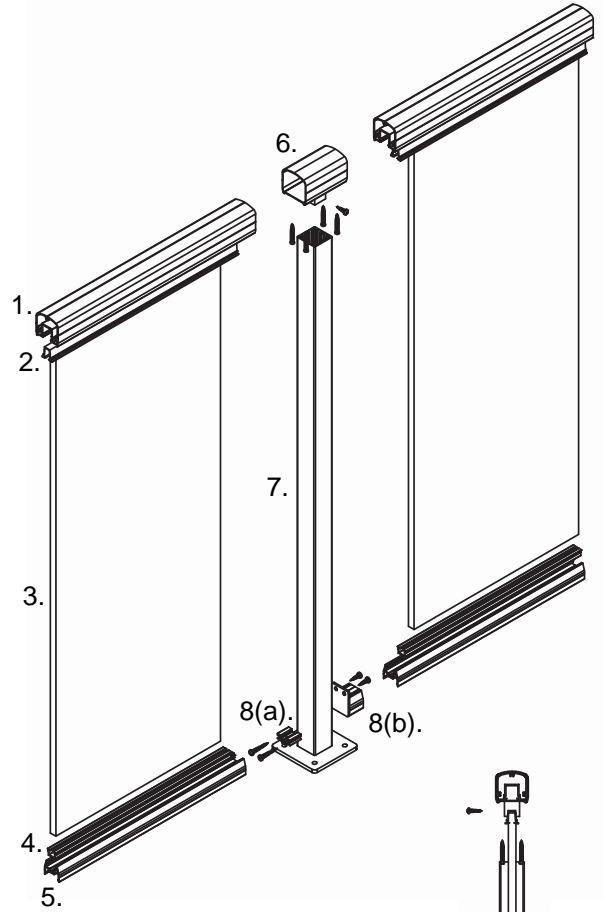
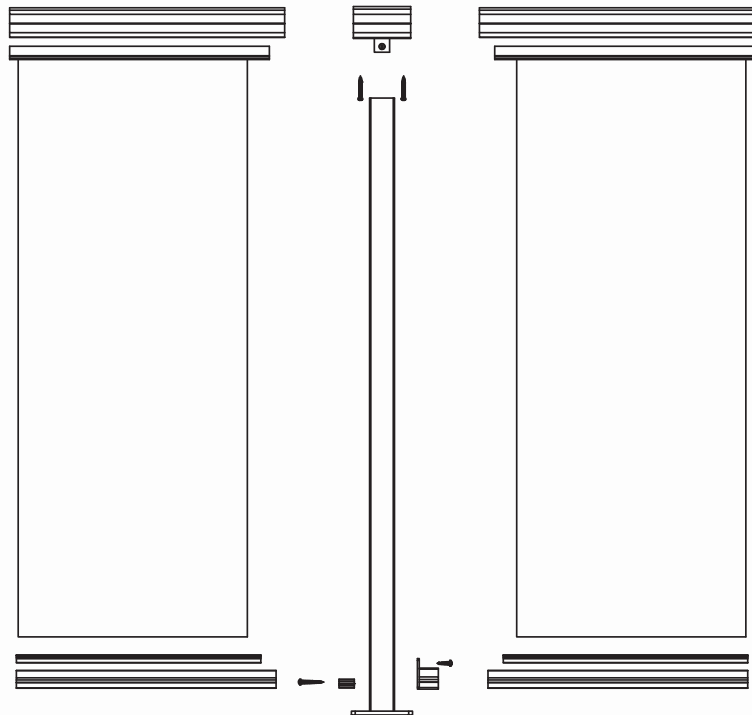
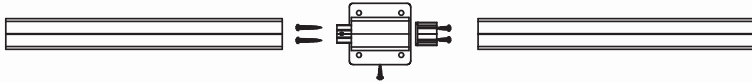

SEE FASTENER SHEET
FOR FASTENER LISTINGS

EXCELLRAILING.COM

Corner Post with Continuous Top Rail Detail - Component Glass

SEE FASTENER SHEET
FOR FASTENER LISTINGS

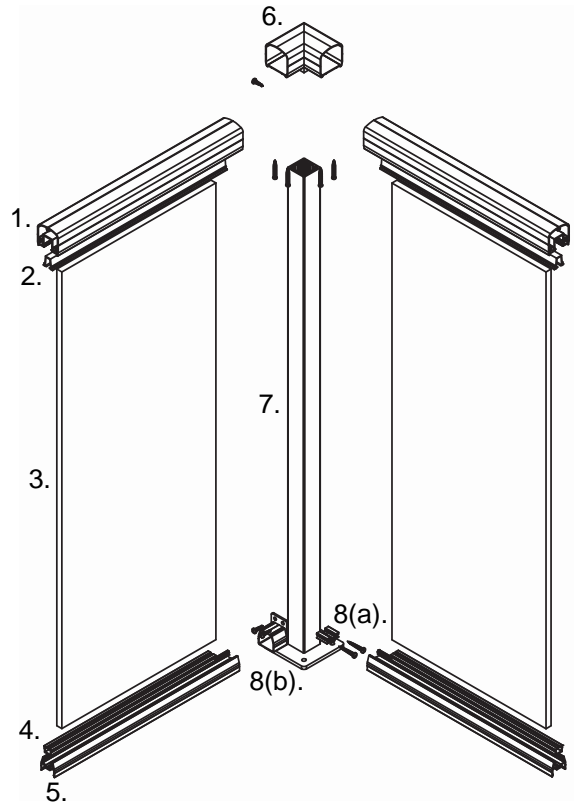
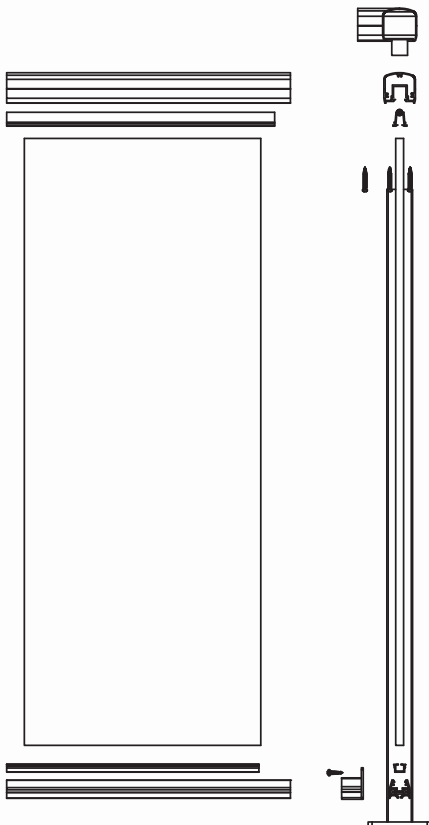
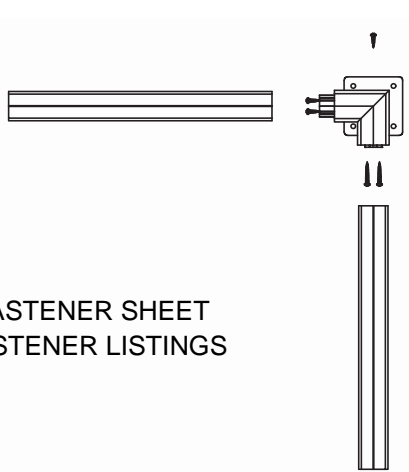

BILL OF MATERIALS

1. Top Rail (Square or Round)
2. Top Glass Insert
3. Tempered Glass (6mm / 1/4")
4. Bottom Glass Insert
5. Component Bottom Rail
6. 90° Top Sleeve
7. Post (2" or Less)
8. (a) Receiver Clip OR (b) Bottom Wall Mount

EXCELLRAILING.COM