

COMPONENT GLASS RAIL

From residential decks to multi-family dwellings to skyscrapers, Excell Railing System's powder-coated aluminum component glass railings can be used in a variety of different applications.

Throughout North America, Excell Aluminum Railings have been relied on as a safe, durable and aesthetically pleasing alternative to steel and wood railings.

Features and Benefits:

- Virtually maintenance free.
- No rust and corrosion.
- 12 standard colors and over 180+ custom colors available.
- Environmentally friendly - powder coated finish with no VOC's.
- IBC Compliant. Fully tested to AC273.
- 20 year structural warranty.
- 10 year limited residential powder coat warranty.

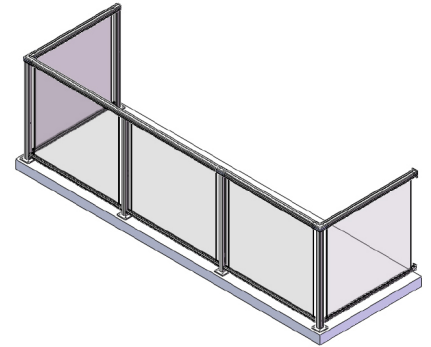

Physical Properties:

- Top Rail: Alloy 6063-T5
- Bottom Rail: Alloy 6063-T5
- Posts: Alloy 6005-T5
- Sleeve Material: Alloy 6063-T5
- Glass Insert: Polyvinyl Chloride (PVC)
- Screws: Stainless Steel
- Glass: 6mm (1/4") Tempered Glass

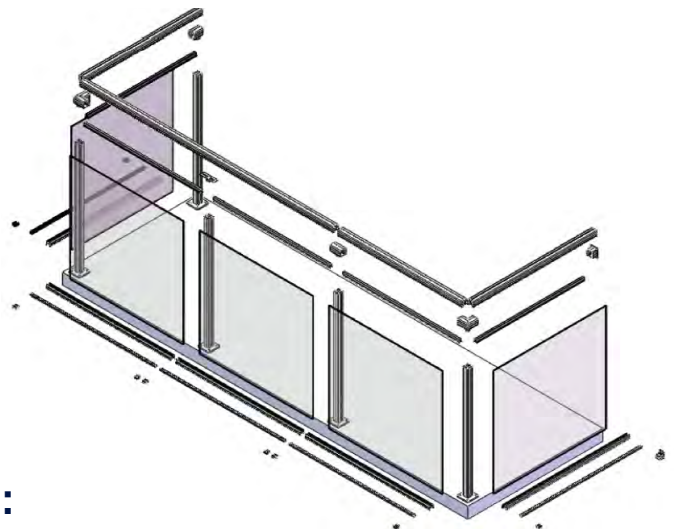

Testing and Compliance Data:

- Code Compliance for IBC 2015 and NBC 2010.

For more details, contact Excell Railing Systems at



1-800-338-3568 | susan@excellrailing.com



1-866-999-7245 | blairh@excellrailing.com